

## Colour Photometry. Part III

W. De W. Abney and E. R. Festing

*Phil. Trans. R. Soc. Lond. A* 1892 **183**, 531-565

doi: 10.1098/rsta.1892.0014

### Email alerting service

Receive free email alerts when new articles cite this article - sign up in the box at the top right-hand corner of the article or click [here](#)

To subscribe to *Phil. Trans. R. Soc. Lond. A* go to: <http://rsta.royalsocietypublishing.org/subscriptions>

XIV. *Colour Photometry*.—Part III.

By Captain W. DE W. ABNEY, C.B., R.E., D.C.L., F.R.S., and Major-General  
E. R. FESTING, R.E., F.R.S.

Received December 14, 1891,—Read January 28, 1892.

§ XLIV.—*Measurement of Luminosity*.\*

IN the paper on *Colour Photometry* (Bakerian Lecture, 1886) a curve of luminosity of the spectrum of the light from the “crater” of the positive pole of the electric (arc) light was given.

The apparatus used for measuring the luminosity was described in that paper, and certain modifications afterwards made were described in the appendix, and in a further paper with the same title in ‘*Phil. Trans.*,’ 1888.

Shortly, the arrangement of the apparatus was as follows : a collimator, two prisms, and lens were used to form a spectrum ; a second lens, placed a little obliquely, re-combined the rays so as to form a white patch 3 inches square on a screen. A slide, having a slit in it, being placed in the spectrum, any ray could be selected and made to fall on the patch.

The beam of white light reflected from the surface of the first prism was, by an arrangement of mirror and lens, made to fall on the same patch. By placing an upright rod in the path of the two beams, one half of the patch was illuminated by the monochromatic ray, and the other by the beam of white light, which, for convenience, we call the “reference” beam, as it has been used throughout our late observations as the standard of reference. The relative luminosity of the two beams could then be compared by reducing one or other by the rotating sectors until the two halves of the patch appeared of equal brightness, the aperture of the sectors being a measure of the proportional brightness of the two beams.

The patch of light was viewed at a distance of somewhere about three feet, its image thus occupied an angular field on the retina of 5°. As all the observations referred to in both papers, whether taken by ourselves or by others, were made with the same apparatus and under similar circumstances, they were strictly comparable

\* The numbering of the paragraphs and figures in this paper is a continuation of that of Parts I. and II., ‘*Phil. Trans.*,’ 1886 and 1888.

with each other, and the angular dimensions of the patch had not to be taken into account.

An extension of the measurements to embrace a part of the physiological aspect of colour has, however, necessitated a slight modification of the apparatus with which a new series of observations have been made. The length of the spectrum, before re-combination, has been more than doubled by using a lens of greater focal length than formerly for collecting the rays proceeding from the prisms. The size of the white surface on which the shadows are received has been reduced to  $1\frac{1}{4}$  inch square, and the observations now recorded were made from a distance of 4 feet from it. This allows the image of the whole of the patch, when viewed direct, to fall on the middle of the yellow spot of the eye, which occupies a central position in the retina, and has an approximate angular aperture of from  $6^\circ$  to  $8^\circ$ . As the absorption of the yellow spot diminishes towards its boundary, it follows that, within certain limits, the smaller the patch that is viewed the greater will be the loss of luminosity in that part of the spectrum where the absorption takes place. From observations made in the manner shortly to be described, it was found that, for our eyes, there was no sensible difference in the results when the two shadows fell on the white square of  $1\frac{1}{2}$  inch side, or a square of 1-inch side, but that, if the side were increased to 2 inches, the measures differed slightly but unmistakably. This will account for the fact that the original luminosity curve slightly differs from that now recorded for the centre of the eye, as part of the image of the larger patch must have fallen on the less absorbing part of the yellow spot. It is not quite apparent why the eye should not distinguish between the differing luminosities of the different parts of the shadows, but it is probable that the average luminosity was observed.

Table I., Col. IV., gives the observed measurements, and fig. 33 gives the curve A plotted from them.

Equalisation of the luminosities of the coloured and white shadows was effected by opening and closing the rotating sectors (which were described in the former paper) in the white beam of light, and confirmation of the measurement was obtained by setting the sectors at fixed angles, thus cutting off definite proportions of white light and shifting the slide carrying the slit which traverses the spectrum till equality of illumination was obtained at each angle so set.

From our experience we believe that the most accurate measurements are those made by altering the angular aperture of the sectors during rotation; as to produce a certain difference of luminosity a greater motion of the hand is required on the lever of the rotating sectors than on the slit in the spectrum. Near the place of maximum luminosity the latter plan fails, as pointed out in our previous paper.

#### § XLV.—*Absorption of the Yellow Spot.*

Though it was not the first inquiry which was undertaken, it will be well thus

early to record the method by which the character and amount of the absorption of the yellow spot was ascertained.

A white spot, very feebly illuminated, was placed six inches from the patch on which the beams to be compared were thrown. One eye was closed and the other directed centrally to the white spot, the observer being at a distance of 4 feet from it. The image of the patch was thus received on a part of the retina beyond the boundary of the yellow spot. It may appear strange to others, as it did to ourselves at first, that the luminosities of the two shadows could be compared with almost greater facility than they could be when looked at centrally. When a comparison was to be made, the presence of colour often appeared not exactly to vanish but to offer no difficulty to the reading. The luminosity was thus determined, and it was found practically that the same curve was obtained in whatever angular position the white spot was placed, so long as it was six inches from the patch. The luminosities of the colours on the patch were also measured when looking directly at them. Any difference between the readings by the eye in the two cases showed a lessened or increased sensitiveness of the central part of the retina under observation for the particular colour. Table I, Col. III., and fig. 33, curve B, gives the results of these observations.

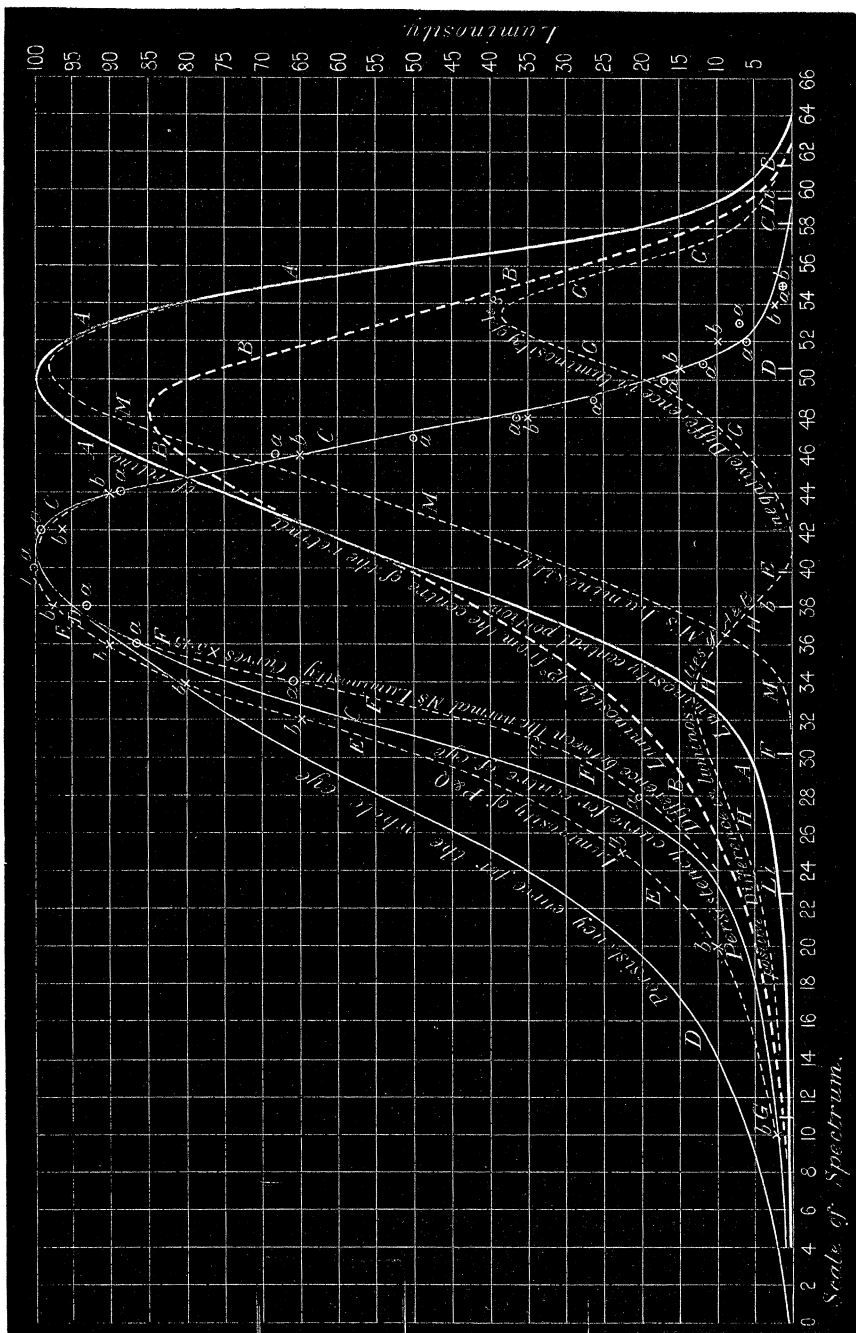
If two square patches of  $1\frac{1}{2}$ -inch side are placed six inches apart, and illuminated with white light of the same intensity, and one be looked at centrally, the image of the other will fall outside the yellow spot.

By diminishing the illumination of one or other, the two may be rendered equally bright to the parts of the retina used, and by first looking at one centrally then at the other, two sets of observations can be obtained. Adopting this plan, and after a large number of estimations (it was necessary to take a large number owing to the difficulty of the observation), it was found that the relative sensitiveness for white light of the centre of the retina to that of the outer part was approximately as 37 to 33. The areas of the curves of luminosity plotted from the readings are in the ratio of 167 to 156, which is so nearly the same ratio that each of their ordinates may be taken to indicate the relative amounts of light seen by either part of the retina in the different parts of the spectrum.

Whilst there is, as might be expected, an increase in the luminosity to the outer part of the retina of the portion of the spectrum from about E to the violet end, over that to the central part of the retina, it is remarkable that the reverse is the case with respect to the portion from the green to the red. Evidently, therefore, the outer part of the retina is less sensitive than the central part to the less refrangible rays of the spectrum. The curve for this part of the retina is very similar to that obtained from the observations made with the centre of the eye by persons who have a slightly shortened spectrum, and who are, therefore, what is termed partially red-blind.

It should be noted that the luminosity curve given in our former paper, and which

Fig. 33.



*a.a.* are observations derived from the luminosity curves of the normal eye and of *M*.

*b.b.* are actual observations of luminosity by *P* and *Q*.

*A*, the luminosity of the spectrum as seen when using the yellow spots.

*B*, " " " " by the retina  $10^\circ$  outside from the centre of the retina.

*C*, " " " " the persistence curve of the normal eye from observations taken with the centre of the retina.

*D*, " " " " " using all the retina.

*E*, " " " " the luminosity curve of *P* and *Q*.

*F*, " " " " the difference between *A* and *M* magnified 5.15 times.

*M*, the luminosity curve of *M*.

*H*, the absorption by the yellow spot.

*G*, the excess of luminosity of the least refrangible end of the spectrum when viewed by the central part of the retina over that when viewed  $10^\circ$  from it.

was made from observations in which the image of the colour patch covered the yellow spot and some of the outer part of the retina as well, lies between the curves A, B, of fig. 33.

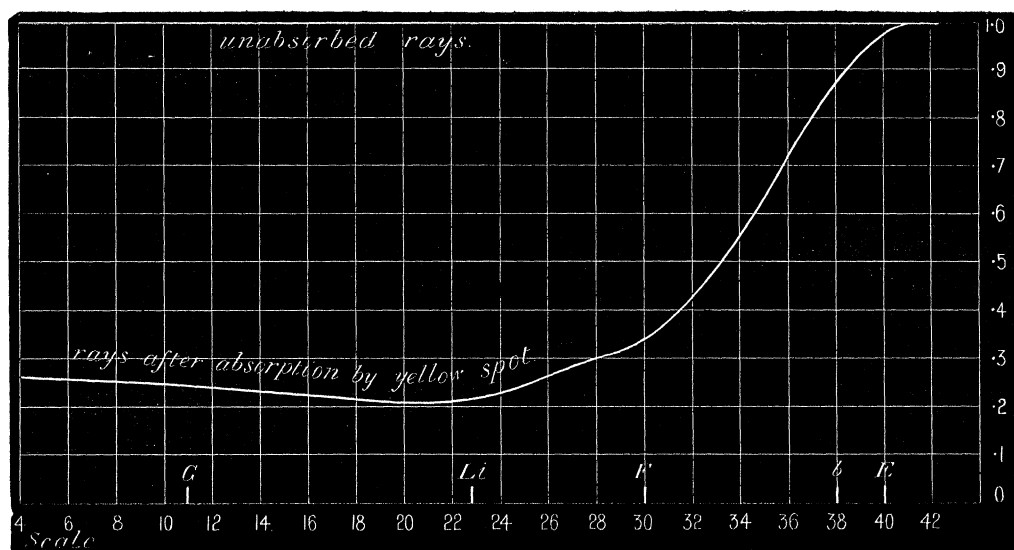
The curve H in fig. 33 shows the absolute absorption of the rays between the green and violet by the yellow spot. Fig. 34 gives the proportionate absorption of the same. The colour of the absorbing medium in the yellow spot can be shown on the screen by using a template cut out in the way described in Colour Photometry, Part II., § XXXV.

TABLE I.—Luminosity Curves.

I.	II.	III.	IV.	V.	I.	II.	III.	IV.	V.
Scale number.	Wave-length.	Outside yellow spot.	Yellow spot.	Fovea centralis.	Scale number.	Wave-length.	Outside yellow spot.	Yellow spot.	Fovea centralis.
64	7217				32	4924	21	8·5	6·5
63	7082	..	1		31	4885	18·5	7·0	5·5
62	6957	1	2	2	30	4848	16·5	5·5	4·0
61	6839	2	4	4	29	4812	14·5	4·7	3·5
60	6728	3·5	7	8	28	4776	13·0	4·0	3·0
59	6621	7·5	12·5	15·5	27	4742	11·5	3·5	2·0
58	6520	12·5	21	24	26	4707	10·5	2·8	2·4
57	6423	19	33	37·5	25	4675	9·4	2·3	2·1
56	6330	27·5	50	60	24	4639	8·2	1·82	1·9
55	6242	35	65	77	23	4608	7·3	1·6	1·5
54	6152	43	80	90	22	4578	6·3	1·4	
53	6074	52·5	90	97	21	4548	5·7	1·2	
52	5996	61·0	96	100	20	4517	5·0	1·08	1·0
51	5219	71·0	99	100	19	4488	4·5	·94	
50	5850	79·0	100	98	18	4459	4·0	·86	
49	5873	84	99	95	17	4437	3·6	·78	
48	4720	85	97	90	16	4404	3·1	·70	
47	5658	83·5	92·5	85	15	4377	2·7	·62	·62
46	5596	81·0	87	79	14	4349	2·3	·56	
45	5538	77·0	81	72·5	13	4323	2·1	·50	
44	5481	72·5	75	66	12	4296	1·9	·45	
43	5427	68·0	69	59	11	4271	1·65	·40	
42	5373	62·5	62·5	51	10	4245	1·4	·34	
41	5321	57	57	45	9	4221	1·2	·30	
40	5270	52	50	40	8	4197	1·0	·26	
39	5221	46	42·5	32	7	4174	·88	·22	
38	5172	41·5	36	27·5	6	4151	·75	·18	
37	5128	37·5	29·5	22·0	5	4131	·63	·16	
36	5085	33·5	24	18	4	4106	·50	·14	
35	5043	30·0	18·2	14	3				
34	5002	26·5	14·2	10	2				
33	4963	24	10·5	8·4	1				

The following are the scale numbers of the different fiduciary Fraunhofer and bright lines :—B 61·3, Li 59·7, C 58·1, D 50·6, E 39·8, b 28, F 30·2, Li (blue) 22·8, G 11·1.

Fig. 34.



Absorption by the macula lutea.

§ XLVI.—*The Fovea Centralis.*<sup>\*</sup>

The question of visual sensation at the fovea centralis, if that be admitted to be coincident with the visual axis of the eye, has occupied our attention, and we have thought it worth while to give the measures of luminosity when the images of the illuminated shadows fell on this portion of the retina. A cube of  $\frac{1}{4}$ -inch side was prepared, and the beams of light allowed to fall on it in the usual manner. The luminosities of the white and coloured shadows were equalised when they were observed at a distance of 60 inches from the eye. One eye was closed during the observations. The measures made are given in Table I., Col. V. It will be noticed the fovea is rather more sensitive to the red rays than the macula lutea, and is in general much less sensitive to the green rays. A calculation of the areas of the curves of luminosity shows that the fovea is  $\frac{1}{6}$  more sensitive to D light than the macula lutea as a whole. It is somewhat remarkable that the sensitiveness to green and blue of the fovea is not greater, and is even less at certain places, than of the macula lutea, considering the almost entire absence of pigment from the former.

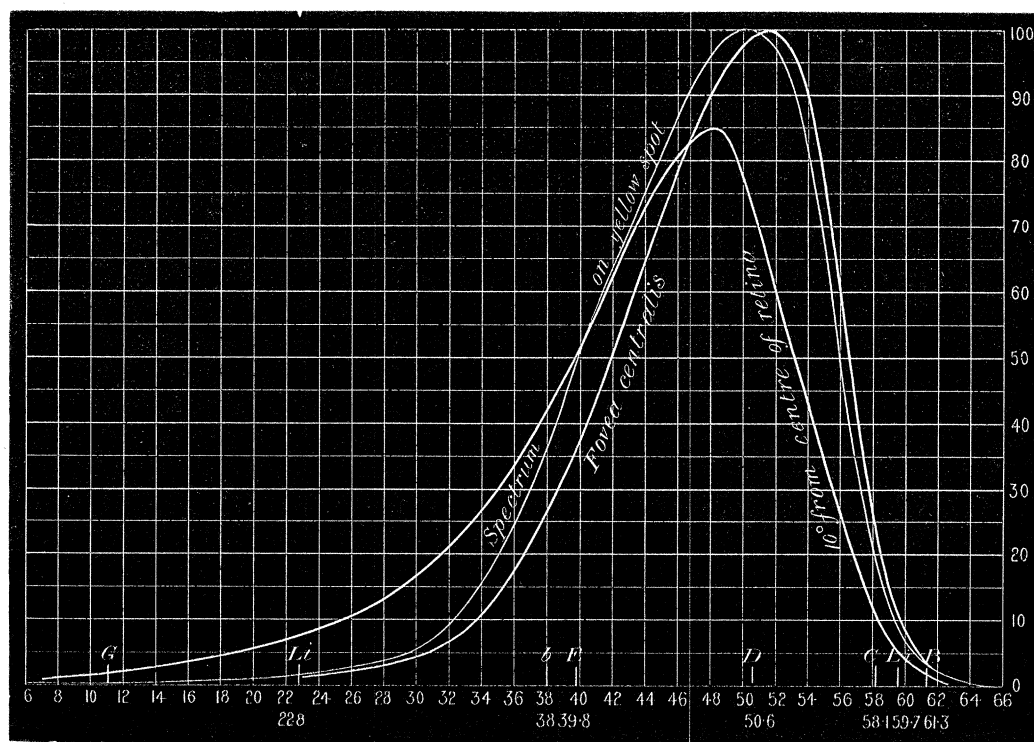
If the small cube be examined at still further distances there is a still further increase in the luminosity of the red and a further decrease in that of the green. What the limit may be where no further change takes place we are not at present prepared to say. If a star or a distant light be observed in the point where the visual axis of the eye cuts the retina, and then on the part of the retina slightly removed from this point, the different colour of the images will be evident.

<sup>\*</sup> Added July 20.

§ XLVII.—*The Limit of Colour Vision.*

It is well-known that as light of any colour becomes enfeebled the eye fails to see colour, though it can recognise the presence of light. From a physical as well as from a physiological point of view, it appeared to be of interest to ascertain the amount of illumination of a screen at which all appreciation of colour in the different rays of the spectrum disappeared, leaving a sensation of what, for want of a better word, we may call *grey light*. In order to ascertain this, an apparatus (fig. 36) was devised as a

Fig. 35.



Curves showing the luminosity of the spectrum when measured (1) with the fovea centralis, (2) with the area of the yellow spot or macula lutea, (3) with the retina  $10^\circ$  from the fovea centralis and outside the macula lutea.

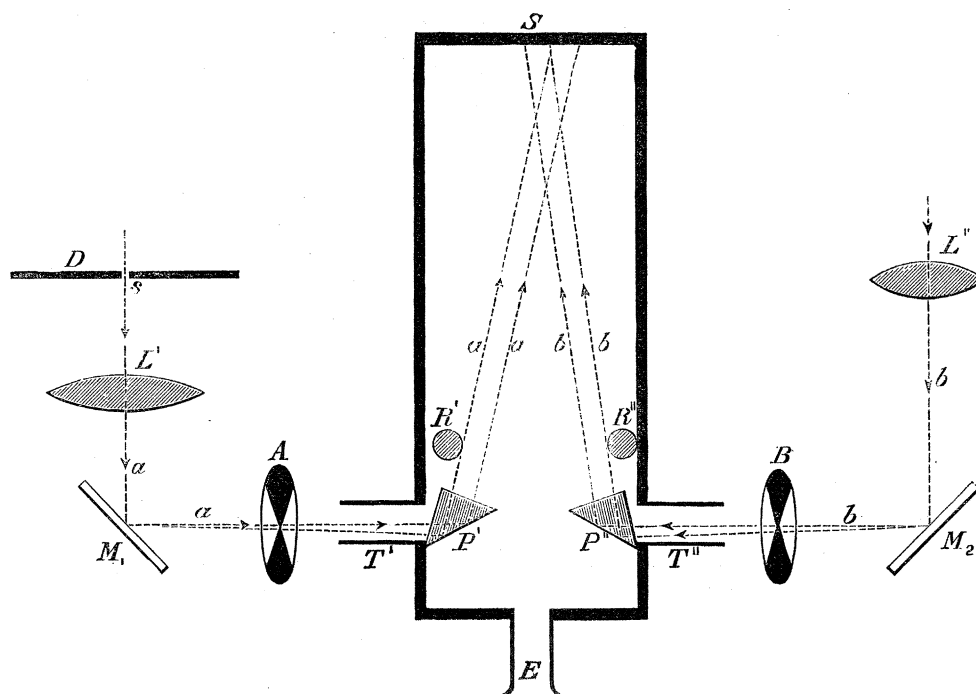
supplement to that already described, by which a white light of very low intensity could be compared with the spectrum colours.

At one end of a box, shown in plan, is an eye-piece E. The other end has at its centre a patch S,  $1\frac{1}{2}$  inches square, whitened with zinc oxide, the rest of the inside of the box being blackened. The monochromatic beam *a* coming from the spectrum through the side slit, and the reference beam *b*, are reflected by plain glass mirrors  $M_1M_2$  to apertures in opposite sides of the box, and from just inside these apertures, by right-angled prisms  $P_1P_2$  so as to fall on and cover S. Rods  $R_1R_2$  are inserted in the box in the paths of the beams so that they illuminate opposite halves of S.



Diaphragms inside the box cut off any stray rays of light, and rotating sectors placed at  $A$  and  $B$  regulate the strength of the beams. The room containing the apparatus is darkened. The sectors  $A$  are closed until no colour is discernible in the monochromatic beam, whilst the intensity of the white beam regulated by the sectors  $B$  gives the standard of whiteness to which the coloured beam is to be reduced. It is worthy of notice that when the white beam is entirely cut off, or made very feeble, colour often seems absent from the monochromatic light, but is again perceived when the beam is brightened. This is especially the case with the red part of the spectrum. The strength of the coloured beam was therefore always reduced to the point that no colour was apparent whatever was the strength of the white beam. The aperture of the sector  $A$  was noted for each colour. The direct measurement of such a feeble

Fig. 36.



Apparatus to measure the limit of colour vision.

light would be very difficult, the luminosity was therefore determined in the following manner. The box and sectors were removed, and a white screen was placed at the same distance from  $M$  that  $S$  was. The card carrying the slit in the spectrum was also removed so that a patch of white light was received on the screen, the luminosity of this was measured by direct comparison with an amyl-acetate lamp. The mirror  $M_1$  was next removed, and the beam then fell on the screen of the original apparatus. Its luminosity was then compared with the reference beam. The slit slide being put back in the spectrum, the luminosity of the  $D$  light was measured against the same comparison light. The proportion that the luminosity of the  $D$  light bore to the

re-combined white patch was thus determined. As the value of the white light reflected from  $M$  to the end of the box was known from the first observation, the luminosity of the D light so reflected was calculated. The luminosity of the D light having been found, that of all the other rays was calculated from the luminosity curve derived from observations made with the central portion of the retina (see fig. 33,  $A$ ), as it was with this part that the observations now being described were made.

The actual value of each ray when the colour disappeared was calculated from the aperture of the sectors.

TABLE II.—Limit of Colour Vision.

Scale number.	Wave-length.	Mean reading of the colour limit of the spectrum D, being 1 amyl lamp in $\frac{1}{100000}$ ths.	Luminosity of the ordinary spectrum.	Luminosity of the rays when each colour disappears, each ray having the original luminosity of 1 amyl lamp in $\frac{1}{100000}$ ths.
61	6839	120	4	48.0
60	6728	67	7	46.9
58	6520	26	21	54.6
56	6330	13	50	65.0
54	6152	9.5	80	76.0
52	5996	9.0	96	86.4
50	5850	9.0	100	90.0
48	5720	9.0	97	87.3
44	5481	9.5	75	71.3
40	5270	10.5	50	52.5
36	5085	12.5	24	30.0
32	4924	18	8.5	15.3
28	4776	32	4.0	12.8
24	4639	55	1.8	12.0
20	4517	90	1.08	9.7
16	4404	160	.70	11.2
12	4296	250	.45	11.0
8	4197	400	.26	10.4
4	4106	700	.14	9.8

In fig. 37 the continuous curve is constructed from these observations,\* and the dotted curve  $B$  is that derived from curve  $A$ , supposing that each ray had an original luminosity of one amyl light at the distance of 1 foot.

It will be seen that the colour of the central portion of the spectrum is discernible with much greater reduction of light than is that of the extremities. This accounts for the fact that objects illuminated by moonlight appear of a greenish hue. The light from the full moon, as is well known, is somewhere about half a million times less bright than that of the sun, or about  $\frac{1}{100000}$  of an amyl lamp at 1 foot. The figure

\* The extreme left end being plotted to a different scale so as to bring it within the paper.

shows that at this point most of the spectrum has lost its colour. The faint spectrum when re-combined will be pale green, mixed, of course, with a fair proportion of grey, due to those portions of the spectrum from which the colour has disappeared.

Fig. 37.

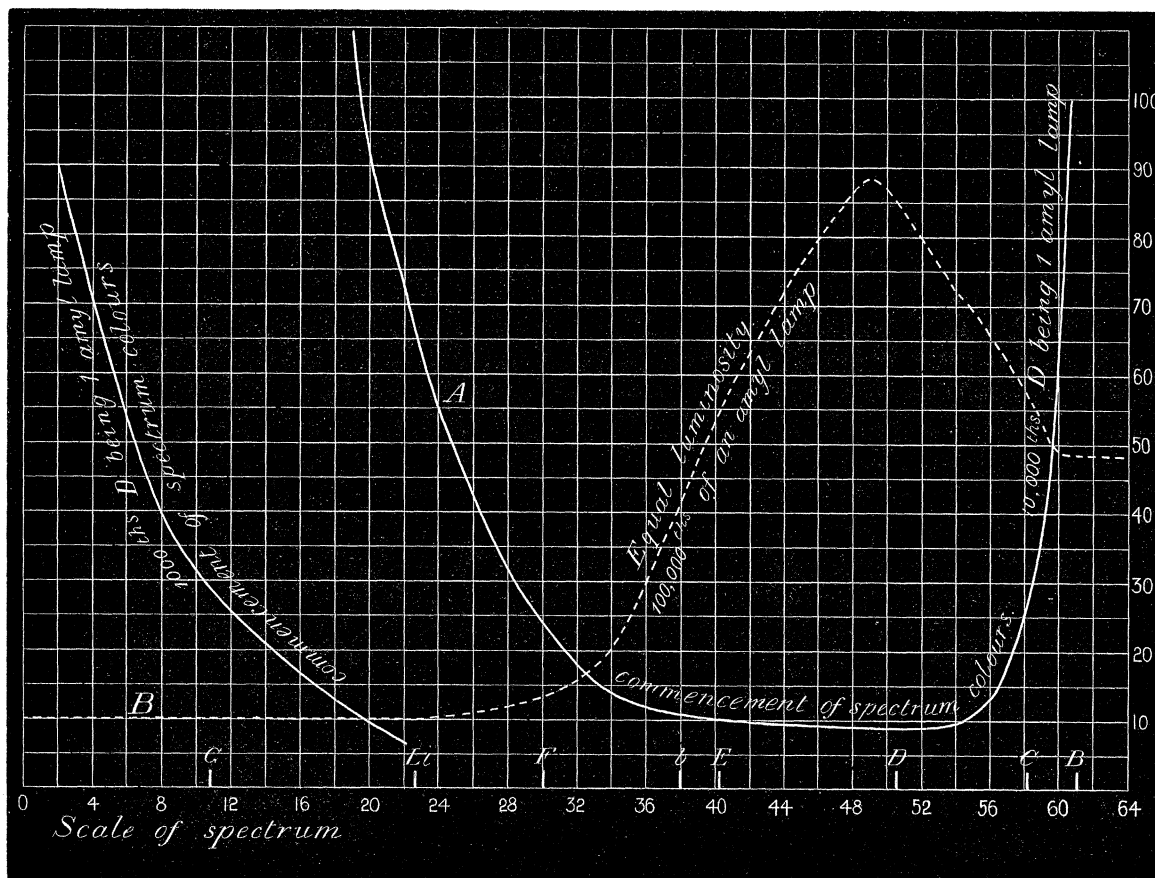


Diagram of limit of colour vision.

### § XLVIII.—*Extinction of the Light of Different Parts of the Spectrum.*

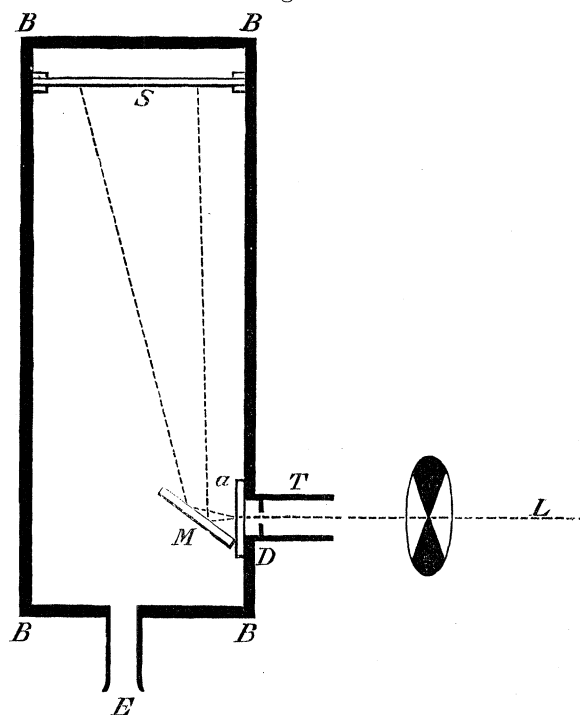
A preliminary note has already been published by one of us (Captain ABNEY) on this subject. It was expected that the results then given might be liable to correction, as in work of this kind it is only after repeated experiment that sources of error can be discovered and eliminated. The errors which have since been discovered by comparing the results of some hundreds of observations are not serious, though their correction alters the extinction curve to some small extent.

In the first experiments the readings of the scale had to be made by the observer, and it has been found that the light used to illuminate the scale, small though it was, fatigued the eye sufficiently to vitiate, to a small but sensible extent, the observations. This source of error has, in the latter experiments, been eliminated.

The necessity of resting the eye for some time in darkness in order to give it the full sensitiveness to feeble light was soon recognised. When extinction has been made and the instrument left untouched, if the eye was exposed to the light of day for some time, and then an observation was made, even after two minutes rest, no light from any ray of the spectrum was visible in the extinction box, even with the sectors removed; after a further rest of two minutes the rays last to be extinguished could be perceived; and finally, after about ten minutes' rest, the eye became of the same sensitiveness as before it was exposed. When several successive extinction readings of the same ray agreed, it was considered that the eye was in a fit state to commence a series of observations.

The apparatus used was usually of the form described below, but variations in its arrangement and in the methods of observations were made from time to time, in order to track out any possible error.

Fig. 38.



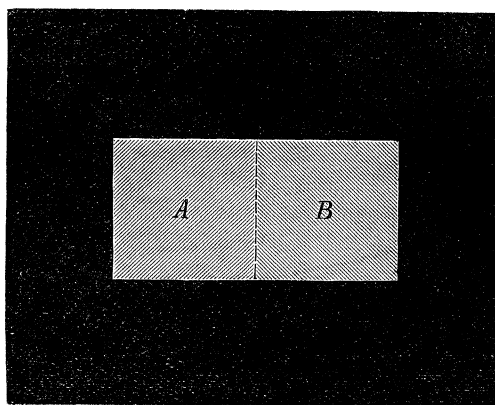
Apparatus to measure extinction of light.

*BB* (fig. 38), is a closed box 3 feet long and about 1 foot wide and 1 foot high, having two circular apertures  $1\frac{1}{2}$  inches in diameter in the positions shown. The aperture at the side is covered on the inside by a piece of glass,  $\alpha$ , finely ground on both sides, and a tube, *T*, is inserted in which diaphragms, *D*, of any required aperture can be inserted. *E* is a tube fixed into the other aperture, and should for comfort be fitted with an end shaped to receive the eye, as the observations are made through it. *S* is a cardboard screen inserted from the top of the box, the

aperture being rendered light-tight by a batten. The screen is black except one circular patch which can be altered at pleasure in colour or size, but which in the experiments now to be described was white and  $\frac{3}{4}$  inch in diameter.

When using this instrument the beam to be extinguished was directed through the tube  $T$  and diaphragm  $D$  on to the ground glass by which it was diffused. A portion of the diffused beam was reflected by the mirror  $M$  to the white patch on the screen at  $S$ . By altering the diaphragm  $D$  the amount of light falling on  $S$  can be varied at pleasure, and it can be still further regulated by putting the rotating sectors in the path of the incident beam outside  $T$ .

Fig. 39.



Screen for measuring illumination.

The point of extinction was observed as follows. The slits of the collimator and of the slide were closed to convenient widths, and the light was subsequently diminished by inserting diaphragms. Two methods of extinction were tried, (1) The slit traversing the spectrum was moved until the ray was found which was just extinguished with each diaphragm; and (2) after placing the slit in fixed positions in the spectrum at a known ray the light was diminished by the rotating sectors as well as by the diaphragms. The latter is evidently the more convenient plan, but both were fully tried in order to determine whether the method of reducing the light by the rotating sectors could be relied on in experiments of this nature. The agreement between the results obtained, which was as close as could be expected in such experiments, convinced us of the trustworthiness of the latter method.

A means had to be devised by which a beam of sufficient intensity to be easily measured could be reduced to the point of extinction, and the proportion in which it had been reduced ascertained. The slit slide was taken away from the spectrum, and the intensity of the re-combined beam determined in terms of the light of the amyliacetate lamp as follows. A card (fig. 39) was pierced with a square aperture  $B$ , as shown, and a piece of Saxe paper pasted over the whole. A black paper mask was then applied, so as to leave  $B$  and an equal area  $A$  visible. From one side the paper

appeared as a white oblong, though  $B$  was translucent and  $A$  opaque. The re-combined beam was then allowed to fall on the back of the card, and  $B$  became illuminated. On the other side of the card an amyl-acetate lamp illuminated  $A$ ,  $B$  being screened by a rod in the path of the light. The brightness of  $A$  and  $B$  were made equal by placing the rotating sectors in the path of the beam of the amyl lamp, and thus the proportion of light passing through the paper was measured in terms of that reflected from a white surface. The card then replaced the screen  $S$  in the box, the end of the box was opened, and  $A$  and  $B$  were exposed to view. The light of the re-combined beam was directed on to  $T$  so as to illuminate  $S$ .  $A$  was made equally bright by the amyl-acetate lamp and the illumination calculated; knowing from the former observation what proportion of the light falling on  $B$  is visible from the other side, the amount of light falling on the screen, and, therefore, its proportion to that received at  $T$  could be determined. Measurements were taken with each diaphragm, and the illumination of the screen in terms of the light received at  $T$ , was found to be proportional to the areas of the apertures, as might be expected, and, as follows, for the diaphragms used:—

No. 0,  $\frac{1}{90}$ ; No. 1,  $\frac{1}{155}$ ; No. 2,  $\frac{1}{208}$ ; No. 3,  $\frac{1}{270}$ ; No. 4,  $\frac{1}{478}$ ; No. 5,  $\frac{1}{620}$ ; No. 6,  $\frac{1}{956}$ ; No. 7,  $\frac{1}{2430}$ .\*

The method of diminishing the illumination of the screen by ground-glass was found to be most effective. A beam of monochromatic light from the brightest part of the spectrum can be diminished to such an extent as to come within the limits of extinction by the rotating sectors, with the apertures of such an angular dimension as to be properly read (say more than  $6^\circ$ ).

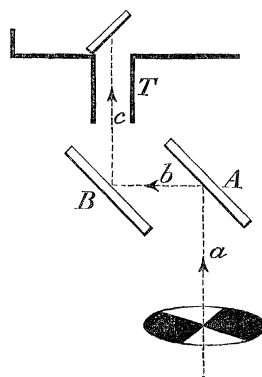
The D light coming through the spectrum slit was measured against an amyl lamp by placing a white opaque screen at the aperture  $a$  (the tube  $T$  being removed). The luminosity of the D light being thus known, that of any other ray could be calculated from the curve  $A$  in fig. 33. Another method of observation was as follows: a diaphragm with a small circular aperture was placed in front of the last prism of the apparatus. The patch of light on the screen was now a small circular disc, instead of being square, as before. A similar box was prepared to that of fig. 38, but the ground-glass was omitted. The ray of light now falling on  $M$  formed a circular patch on the screen  $S$ , but the beam of light so formed is too powerful to be extinguished by any readable aperture of the rotating sectors, it was therefore further reduced by placing in its path, and at an angle of  $45^\circ$  to it, two parallel mirrors  $A$ ,  $B$  (see fig. 40). Each mirror can be either silvered or plain glass; three combinations of different reducing powers are therefore possible, viz.: ( $a$ ) both mirrors silvered, ( $b$ ) one plain and one silvered, ( $c$ ) both plain.

The proportion of the light reflected with each combination can be readily deter-

\* [This method of measuring the ratio of light falling on the screen to that on the ground glass has been subsequently modified, the two being directly compared one with the other.—July 20.]

mined. When the last was used the intensity of  $c$  was almost exactly  $\frac{1}{100}$  of that of  $a$ . As the rotating sectors gave a further extreme reduction of, say,  $\frac{1}{15}$ ,  $a$  could be used of a manageable intensity.

Fig. 40.



Method of double reflection into extinction box.

When employing this method the collecting lens in front of the spectrum was so adjusted, that the re-combined beam from the whole spectrum formed a circular spot on  $S$ , the position of the spot of light on  $S$  was, therefore, the same for all parts of the spectrum.

The absolute luminosity of the beam from  $D$  of the spectrum was measured by placing an open screen at the same distance from the mirror  $M$  (fig. 38) that  $S$  was, two silvered mirrors being used at  $A$  and  $B$ , and using the amyl-acetate lamp for comparison. The absolute luminosities of beams from other parts of the spectrum were then calculated from this by means of the luminosity curves, fig. 33.

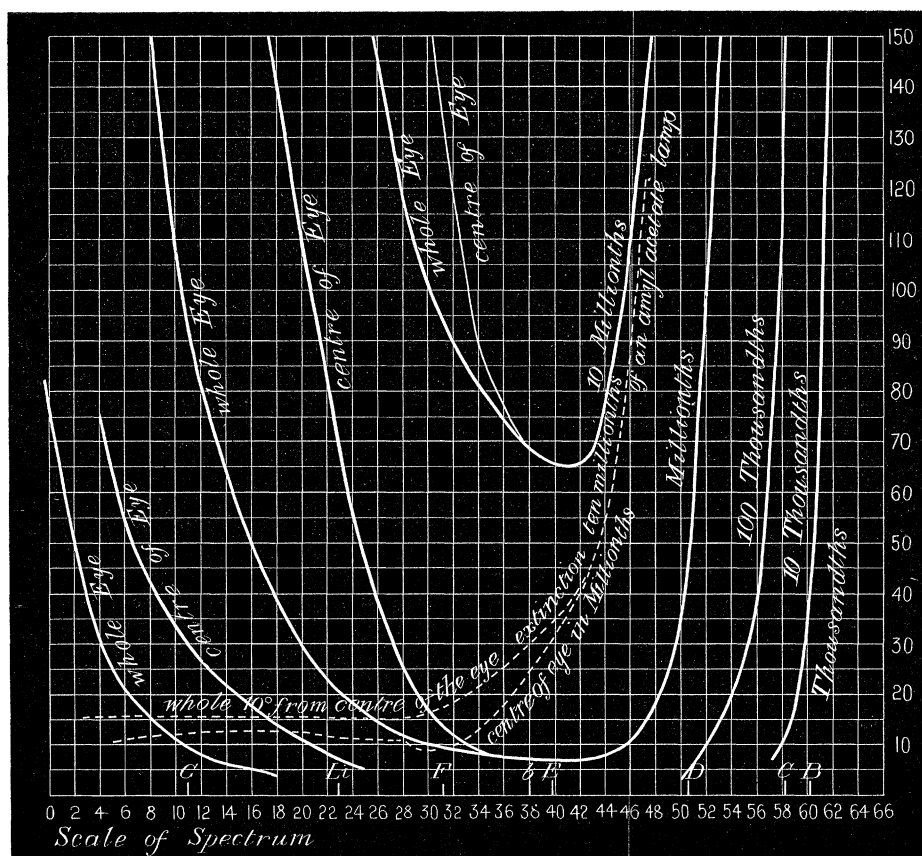
The results obtained by using the rotating sectors with this apparatus were also tested by the method before described, and were found to be perfectly trustworthy.

From the observations made, a curve was plotted showing what was the proportion of the beam from each part of the spectrum which was just not visible. The absolute luminosity of each part of the spectrum having been determined in the way explained above, a second curve was plotted of which the ordinates represent the absolute luminosity of each part of the spectrum at the extinction point, or, in other words, the proportion which would be just not visible, supposing that each part had been originally of the uniform luminosity of, say, one candle. This curve rose from the blue-green towards the red, when, after reaching a maximum, it tended to drop again. There appeared to be a similar irregularity at the violet end. It was suspected that these irregularities might be caused by some admixture of white light due to want of perfect transparency of the prisms, and further investigation showed that this was the case, and that when this stray white light was eliminated the curve became of the form shown by the dotted line, fig. 41.

HELMHOLTZ'S plan of dispersing this white light was first tried. A prism was placed in the path of the beam from the collecting lens at such a distance that the beam

filled the prism, and by using a second lens the faint, continuous spectrum so formed was cut off. This plan was found, however, to be too complicated, and was abandoned for the simpler one of using absorbing media. A combination of "cobalt blue" and "signal green" glass was used for the violet end of the spectrum, and "stained-red" glass—*i.e.*, glass flashed on one side with copper, and on the other with gold—for the red end.

Fig. 41.



Extinction curves of normal eye.

The continuous line curves show the proportion of the beam from each part of the spectrum which is just not visible, the illumination by the beam from D when unreduced being equal to that of one amyli-acetate lamp at one foot from a screen.

The dotted curves show the proportion, supposing that all beams had equal intensity to that of D.

The luminosity of each beam after passing the medium was determined, also the proportion left when it was reduced so as just to extinguish the light, the product of the numbers representing these quantities would evidently represent the absolute luminosity at the point of extinction, or, in other words, the proportion left on the supposition of a uniform luminosity for all parts of the spectrum.

Tables III. and IV. give the results of these observations with which the observations of Table V. are combined. The figures in the third column represent the



proportion to which each beam was reduced at extinction, those in the fourth column the absolute luminosity of the beam. The last column gives the products of these two quantities, which are the luminosities at the extinction point.

TABLE III.—Extinction by Central Portion of Normal Eye.

I.	II.	III.	IV.	V.	VI.
Scale number.	Wave-length.	E. Reduction of original luminosity in millionths to cause extinction.	L. Luminosity of original beam.	$\frac{E \times L}{100}$ .	Persistency curve $\frac{650}{E}$ (Maximum = 100).
64	7,217	55,000			
63	7,082	30,000	1	300.0	
62	7,957	15,000	2	300.0	
61	6,839	7,500	4	300.0	
60	6,728	3,750	7	262.5	
59	6,621	1,900	12.5	237.5	.34
58	6,520	1,050	21	220.5	.62
57	6,423	650	33	214.5	1.0
56	6,330	380	50	190.0	1.71
55	6,242	272	65	176.8	2.38
54	6,152	196	80	156.0	3.32
53	6,074	140	90	126.0	4.64
52	5,996	97	96	93.12	6.70
51	5,919	57	99	56.43	11.40
50	5,850	35	100	35.0	18.6
49	5,783	24	99	23.76	27.1
48	5,720	17	97	16.49	38.2
47	5,658	12.6	92.5	11.65	51.6
46	5,596	10.2	87	8.87	63.7
45	5,538	8.6	81	6.97	75.6
44	5,481	7.4	75	5.55	87.8
43	5,427	6.7	69	4.62	97.0
42	5,373	6.55	62.5	4.09	99.5
41	5,321	6.5	57	3.705	100
40	5,270	6.55	50	3.27	98.5
39	5,221	6.65	42.5	2.83	97.5
38	5,172	6.85	36	2.46	95.0
37	5,128	7.2	29.5	2.12	90.0
36	5,085	7.6	24	1.82	81.3
35	5,043	8.15	18.2	1.48	80.0
34	5,002	8.8	14.2	1.25	74.0
33	4,963	10.2	10.5	1.07	63.0
32	4,924	11.6	8.5	.988	56.0
31	4,885	13.6	7.0	.952	47.7
30	4,848	16.3	5.5	.896	40.0
29	4,812	20.5	4.7	.963	31.7
28	4,776	26.0	4.0	1.040	25.0
27	4,742	31.0	3.5	1.085	20.9
26	4,707	38.5	2.8	1.078	16.9
25	4,674	46.0	2.3	1.058	14.1
24	4,639	56.0	1.82	1.019	11.6
23	4,608	67.0	1.6	1.072	9.7

## ON COLOUR PHOTOMETRY.

547.

TABLE III. (continued).

I.	II.	III.	IV.	V.	VI.
Scale number.	Wave-length.	E. Reduction of original luminosity in millionths to cause extinction.	L. Luminosity of original beam.	$\frac{E \times L}{100}$ .	Persistency curve $\frac{650}{E}$ (Maximum = 100).
22	4578	80	1·4	1·120	8·41
21	4548	95	1·2	1·140	7·22
20	4517	107	1·08	1·156	6·1
19	4488	124	·94	1·165	5·23
18	4459	140	·86	1·204	4·64
17	4437	160	·78	1·228	4·1
16	4404	180	·70	1·260	3·60
15	4377	200	·62	1·240	3·25
14	4349	220	·56	1·232	2·95
13	4323	240	·50	1·200	2·7
12	4296	270	·45	1·215	2·4
11	4271	300	·40	1·200	2·18
10	4245	335	·34	1·139	1·94
9	4221	375	·30	1·125	1·73
8	4197	430	·26	1·118	1·51
7	4174	490	·22	1·078	1·32
6	4151	510	·18	·918	1·27
5	4131	640	·16	1·024	1·01
4	4106	750	·14	1·050	0·86

TABLE IV.—Extinction by Whole Eye.

I.	II.	III.	IV.	V.	VI.
Scale number.	Wave-length.	E. Reduction of original luminosity in millionths to cause extinction.	L. Luminosity of original beam.	$\frac{E \times L}{160}$	Persistency curve $\frac{650}{E}$ (Maximum = 100).
38	5172	6.9	41.5	2.86	94.2
37	5128	7.1	37.5	2.66	91.6
36	5085	7.4	33.5	2.48	87.8
35	5043	7.7	30.0	2.31	84.4
34	5002	8.0	26.5	2.12	81.2
33	4963	8.4	24.0	2.02	77.5
32	4924	8.8	21.0	1.85	73.8
31	4885	9.4	18.5	1.74	69.2
30	4848	10.0	16.5	1.65	65.0
29	4812	10.7	14.5	1.55	60.6
28	4776	11.5	13.0	1.49	56.5
27	4742	13.0	11.5	1.49	50.0
26	4707	14.5	10.5	1.52	44.8
24	4639	18.5	8.2	1.52	34.1
22	4578	23.0	6.3	1.45	28.3
20	4517	30.0	5.0	1.50	21.7
18	4459	39.0	4.0	1.56	16.7
16	4404	51	3.1	1.59	12.3
14	4349	66	2.3	1.52	9.85
12	4296	80	1.9	1.52	8.12
10	4245	110	1.4	1.54	5.91
8	4197	154	1.0	1.54	4.22
6	4151	204	.75	1.54	3.18
4	4106	307	.5	1.54	2.11
2	4063	513	.3	1.54	1.26
0	4020	770	.2	1.54	.84

TABLE V.—Extinction Curves of Light transmitted through Blue and Red Glasses.

Scale number.	Wave length.	Reduction to produce extinction, E. (Sector readings).	Comparative Luminosities of unreduced beams, L.	E × L.	
through blue glass.	14·5	4363	4	148	592
	13·5	4336	4·5	132	594
	12·5	4309	5	120	600
	11·5	4284	5·5	108	594
	10·5	4258	6·2	96	595
	9·5	4233	7·0	86	602
	8·5	4209	8·0	76	608
	7·5	4186	8·8	68	594
	6·5	4163	9·8	62	617
	5·5	4141	11·0	56	616
	4·5	4118	12·0	50	600
	3·5	4094	13	45	585
	2·5	4070	16	37	592
	1·5	4047	19	35·5	598
	·5	4025	25	24	600
— ·5	4023	35	17	595	
through red glass.	64	7212	73	8	584
	63·5	7147	45	13	585
	62·5	7022	25	23	575
	61·5	6900	12	49	588
	60·5	6785	5·5	101	555
	59·5	6675	3	168	504

From Table V. it is seen that from the extreme violet end of the spectrum, to No. 14·5, the luminosities of extinction are practically the same; in fact the curve at this part is horizontal; the same is the case with regard to the part between scale No. 61·5 and the extreme red end of the spectrum.

This seems to confirm the view that the colour sensation of the eye for each of these parts is a simple one. These results have been, as already said, incorporated in Tables III. and IV.

In the diagrams, fig. 41, two curves of extinction are given. One shows what proportion of the beam, at different parts of the spectrum, is just not visible to the central portion of the eye, the other, the curve with regard to the *whole* eye. These curves correspond with each other, except where the absorption by the yellow spot takes place. The part of the retina which appears most sensitive to the light of this part of the spectrum is about 20° below the centre, and about 45° from the vertical line. The light is certainly most persistent at this point.

If the reciprocals of the ordinates of either of the curves just referred to—that is to say, of the reduction of the beam at different points—be taken as ordinates, the curve so constructed may be called a “persistence” curve, and should relate to some colour sensation in our eyes. Such curves (with ordinates so reduced that the

maximum is 100) were constructed for the centre of the eye, and for the whole eye (fig. 33, C, D). Column VI. in the tables gives the ordinates.

§ XLIX.—*Extinction of Light to the Colour Blind.*

In a paper in the ‘Proc. Roy. Soc.’ (1891) one of us has given a curve of luminosity of the spectrum as seen by two brothers whose sensation was monochromatic. On comparing this with our persistency curve for the centre of the eye (which must represent the luminosity of the spectrum to some sensation which we have), we were surprised to find that the curves corresponded except in the yellow spot absorption portion, when ours fell below theirs, see fig. 33. It, therefore, appears that the sensation of the two brothers very nearly corresponds with what must be the dominant sensation in our eyes.

Before commenting on this, it will be of interest to give a further confirmation of the existence of this one sensation. A gentleman, whom we will call M., had his vision tested. His is a case we have never tested before, and is most remarkable. The only two colours he saw are what he called red and black. He called all green and blue black, green however he called bright black, blue being described as a darker black. Yellow he called white. At 52 on the scale he saw a “little red,” at 50 “no colour”; his neutral point—if it may be so called—or the point where he saw the spectrum colourless, would be about 495 or about 5800.

His luminosity curve is given at M, fig. 33. The following is the table from which it was plotted. The mean readings being multiplied by 1·8, the curve of luminosity of the red part of the spectrum almost exactly coincides with that of the authors.

Column I. gives the scale number, II. the wave-length, III. the actual mean reading, IV. the last  $\times 1\cdot8$ , V. the ordinates of the normal luminosity curve of the central part of the eye, VI. the difference between M.’s curve and the normal luminosity curve, whilst VII. gives the difference multiplied by 5·15 to bring the maximum to 100 for comparison with other curves. It will be seen that this curve (F., fig. 33) very nearly coincides with our persistency curve, except in the part of the spectrum affected by the yellow spot.

No measures were taken to ascertain if the eye of M. had any central absorption, and, therefore, we do not know what correction should be made to the curve to make it comparable with the others; but taken as it is, it is remarkable how closely this, which represents the deficiency in M.’s sensations, corresponds with the one sensation of either of the brothers. In fact, it seems as if the eyes of M. and P. together would make up a pair of normal eyes.

TABLE VI.—M.'s Luminosity Curve compared with the Normal.

I.	II.	III.	IV.	V.	VI.	VII.
Scale number.	Wave-length.	Mean reading.	Mean reading $\times 1.8$ .	Normal luminosity curve, centre of eye.	Difference of last two columns.	Cifference $\times 5.15$ .
61	6839	2	3.6	4	.4	2.57
59	6621	7	12.6	12.5	-.1	.51
57	6423	18	32.4	33	+.6	3.09
55	6242	36	64.8	65	.2	1.03
53	6074	49	88.2	89.5	1.3	6.71
52	5996	52	95.4	96.5	1.1	5.66
51	5919	54	97.2	99.5	2.3	11.8
50	5850	54	97.2	100	2.8	14.4
49	5782	52.5	94.5	99.5	5.0	25.7
48	5720	50	90	97	7.0	36.0
47	5658	46	82.8	92.5	9.7	49.9
46	5596	41	73.8	87	13.2	68.0
44	5481	32	57.6	75	17.4	89
42	5373	23	43.2	62.5	19.3	99
40	5270	17	30.6	50	19.4	100
38	5172	10	17.5	35.5	18	93
36	5085	4	7.2	24	16.8	86.5
34	5002	1.0	1.8	14.5	12.7	65.5
31	4885	.5	.7	6.5	5.8	37.7
28	4776	0	0	4	4	20.6

A further examination into cases of colour-blindness cannot fail to be interesting, and appears to us to throw considerable light on the subject of colour vision.

Several red and green colour-blind people have been tested in the manner described, but the difficulty in many cases of inducing them to note whether the observations of extinction were made with the whole eye or the central part only, was very great, and there has, therefore, been some uncertainty as to the results.

We give, however, the results in three cases which may be considered typical, and in which the observations appear to have been extremely well made. The first (H. R.) is red blind, the second (V. H.) green blind, the third (P.) has monochromatic vision. The first two were educated men who understood exactly what they had to look for, the last (one of the brothers P. and Q.) was an excellent observer, sharp and intelligent, and anxious to help on the experimenter. (See Tables VII., VIII., and IX.)

We are aware that the YOUNG-HELMHOLTZ theory of vision is open to criticism from certain points of view, but we adopt it tentatively as being at least convenient.

On this theory we should expect, if the monochromatic vision of the third was supposed to consist of the blue (or violet) sensation, that all three of the observers would give approximately the same curves in the most refrangible part of the spectrum, since in the red blind and green blind this same sensation may be supposed to be existent. That the monochromatic sensation is blue, and corresponds to the dominant sensation

in the normal eye seems to be fairly probable. A glance at the extinction curves of the spectrum shows how similar in many respects P.'s is to those of H. R. and V. H., as well as to that of the normal eye. It is also worth remarking that if a bright red and blue be mixed together by rays coming through two slits placed in the spectrum, so as to form a reddish purple, the red sensation is extinguished some time before the blue pales to any great degree, and in that part of the spectrum where the existence of this monochromatic sensation is evident, the last colour visible is always bluish even when very faint, whilst in the yellow part of the spectrum there seems a tendency before extinction for a greenish hue to appear, whereas, almost to the moment of extinction in the extreme red, the colour is of a ruddy grey. The strongest evidence, however, is to be found in the persistency curves of the red and green blind, which only slightly differ from one another and from that of the normal eye, and to an extent which might be expected from the nature of the observations. The persistency curve (fig. 43) of V. H. differs but little in any respect from the normal, and this tends to show that the persistency is far greater in the blue sensation than in the green, in other words, that the green part of the spectrum excites the blue sensation in the normal eye after the light has been so much reduced that the green sensation has ceased to be excited. V. H. is the first case in which the total absence of a green sensation is an established fact, and the probable luminosity of such green sensation is derived by subtracting the ordinates of his curve from those of the curve of the normal eye. That H. R. is not *totally* red blind, we have on several occasions had the opportunity of proving. He has a slight perception of red, and hence the difference between his curve and that of the normal eye cannot be treated in the same manner, as it would not represent the luminosity of the red sensation in its entirety. Tables VI., VII., VIII. give the observations made by P., V. H., and H. R. respectively, and figs. 43, 44, 45 give their luminosity and extinction curves, together with the normal luminosity curve for the centre of the eye.

The persistency of the blue sensation, or, we might say, perhaps, of the sensation which is confined principally to the most refrangible part of the visible spectrum, is very remarkable, and affords some clue to the reason of the disappearance of the red and green before the blue in cases of colour-blindness induced by disease.

We believe it probable that, adopting the YOUNG-HELMHOLTZ theory, the three colour sensations obtained from these observations by colour-blind people can be made to form the luminosity curve of the normal eye, and, at the same time, to be in accordance with the colour equations which have been found by CLERK MAXWELL, as well as by ourselves.

M.'s observations of extinction were sometimes erratic, and we therefore cannot make much use of the results. But they appear to afford proof that his dominant sensation is not more than  $\frac{1}{180}$  as powerful as that of the normal eye, and may even be considerably less. An inspection of his results also shows that the extinction of the part of the spectrum in the red very closely resembles that of the normal eye in

## ON COLOUR PHOTOMETRY.

553

character and in amount. What is M.'s dominant sensation is not quite apparent, for, although he described the light between E and D as "white" when of ordinary intensity, yet he averred that it always appeared ruddy at the moment of extinction.

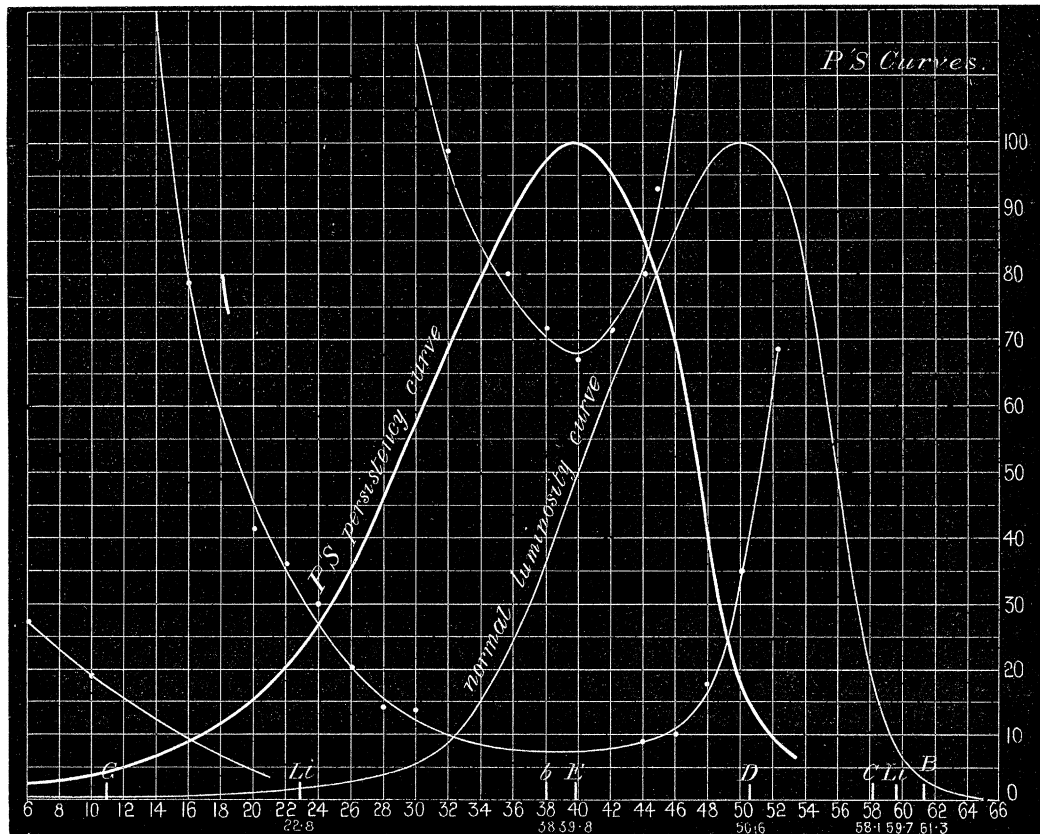
TABLE VII.—P.'s Curves.\*

I.	II.	III.	IV.	V.	VI.	VII.
Scale number.	Wave-length.	Mean reading of extinction in millionths of original luminosity.	Adopted reading in millionths of original luminosity.	Persistency curve $\frac{680}{\text{ad. reading}}$ .	P.'s luminosity curve.	Absolute luminosity of extinction $\frac{\text{IV.} \times \text{VI.}}{14}$ .
52	5996	68	68	10	7	34
50	5850	35	35	19.4	19	47.5
48	5720	17	17	40	39	47.3
46	5596	10.2	10	68	65	46.4
45	5538	9.3	9.0	76	76	48.8
44	5481	8.0	8.1	84	90	52.8
42	5373	7.2	7.2	94.5	98	50.3
40	5270	6.7	6.8	100	99	48.1
38	5172	7.2	7.0	97	97.5	48.7
36	5085	8.05	7.7	90	90	49.5
34	5002	8.05	8.4	81	80	47.9
32	4924	9.9	9.8	69	65	45.5
30	4848	13.2	12.5	54	50	44.6
28	4776	13.9	15.0	45.3	36	38.6
27	4742	16.8	17.0	40	31.5	38.2
26	4707	21.6	20.5	32	26.5	38.8
24	4639	30	27	25	19.5	37.6
22	4578	36	35	19	14	35
20	4517	42	45	15.5	10	32.2
16	4404	79	79	8.5	5.5	31.2
10	4245	180	190	3.6	2.5	32.2
6	4151	270	270	2.7		

\* In this and the next two Tables the intensity of the illumination of the D ray before reduction is equal to that of an amyl-acetate lamp at one foot from a screen. The figures in Col. VII. are in millionths of the illumination of an amyl-acetate lamp at one foot distant, every ray being made of that intensity.

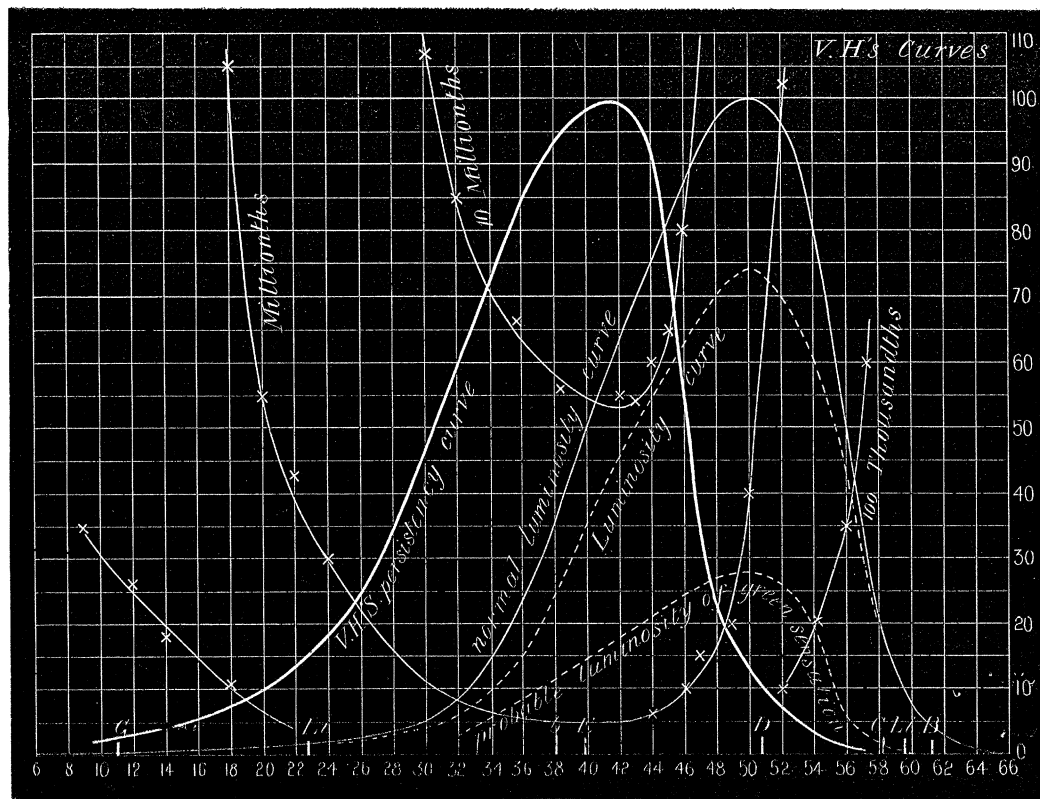


Fig. 42.



Extinction curve of monochromatic vision.

Fig. 43



Extinction and luminosity curves of a green blind.

## ON COLOUR PHOTOMETRY.

555

TABLE VIII.—V. H.'s Curves.

I.	II.	III.	IV.	V.	VI.	VII.
Scale number.	Wave-length.	Mean reading of extinction in millionths of original luminosity.	Adopted reading in millionths of original luminosity.	Persistency curve $\frac{530}{\text{ad. reading}}$ .	Luminosity curve.	Absolute luminosity of extinction $\frac{\text{IV.} \times \text{VI.}}{75}$ .
57	6423	500	500	1.1	31	206
56	6330	350	350	1.5	43	200
54	6152	200	180	2.9	61	146.4
52	5996	100	100	5.3	70	93.3
50	5850	40	40	13.3	73	38.9
48	5720	..	25	21.2	69	23
46	5596	10	10	53.0	63	8.4
45	5538	6.5	6.5	81.6	58	5.0
44	5481	6.0	5.7	93	54	4.1
42	5373	5.5	5.3	100	46	3.3
40	5270	5.5	5.4	98.2	36	2.6
38	5172	5.7	5.7	93	24	1.8
36	5085	6.7	6.5	81.6	15	1.3
34	5002	7.0	7.0	75.7	9.5	.89
32	4924	8.5	8.5	62.3	7.0	.79
30	4848	10.7	10.5	50.5	5.0	.70
28	4776	16	16	33.1	3.7	.79
26	4707	..	22.5	23.5	2.7	.81
24	4639	30	31	17.1	1.82	.75
22	4578	42.5	42	12.6	1.4	.78
20	4517	55	55	9.6	1.0	.73
16	4404	105	100	5.3	.7	.93
12	4296	175	170	3.1	.45	1.02
10	4245	200	200	2.7	.34	.91

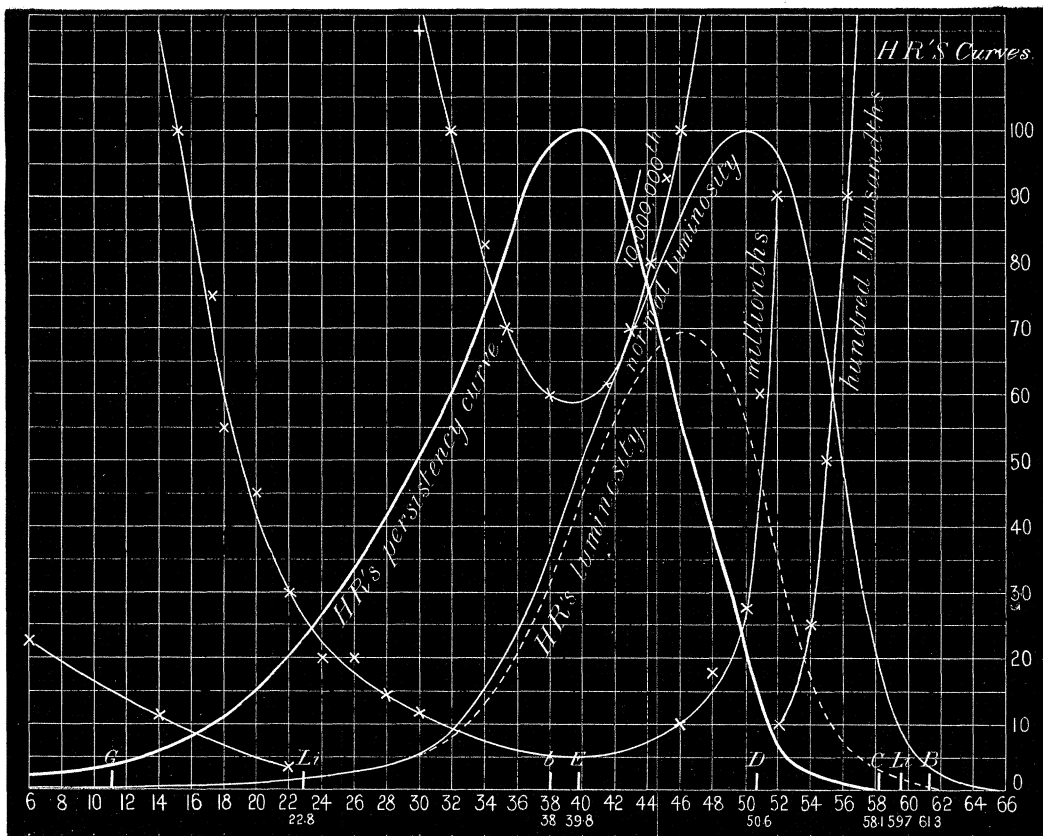
TABLE IX.—H. R.'s Curves.

I.	II.	III.	IV.	V.	VI.	VII.
Scale number.	Wave-length.	Mean reading of extinction in millionths of original luminosity.	Adopted reading in millionths of original luminosity.	Persistency curve $\frac{590}{\text{ad. reading}}$ .	Luminosity curve.	Absolute luminosity of extinction $\frac{\text{IV.} \times \text{VI.}}{48}$ .
57	6423	1200	1200	·49	5	125
56	6330	900	850	·69	7	124
55	6242	500	550	1·07	10	115
54	6152	250	250	2·36	17	88
53	6074	..	150	3·93	25	78
52	5996	90	90	6·56	35	66
51	5919	60	45	13·1	47	44
50	5850	27	27	21·8	57	32
48	5720	18	15	39·3	66	21
46	5596	10	10	59	69	14
44	5481	9·3	8	73·8	64	11
42	5373	6·5	6·2	95·1	56·5	7
40	5270	5·9	5·9	100	45	5·5
38	5172	6	6	98·3	32	4
36	5085	..	6·6	89·4	20	2·7
35	5043	7	7·2	81·9	16	2·4
34	5002	..	8	73·8	12·5	2·1
32	4924	10	9·6	61·5	8	1·6
30	4848	11·5	12	49·2	6	1·5
28	4776	14·5	14·5	40·7	5	1·5
26	4707	20	17·5	33·7	4	1·5
24	4639	20	22	26·8	3	1·4
22	4578	..	30	19·7	2·4	1·5
18	4459	55	57	10·4	1·3	1·5
14	4349	115	115	5·1	·7	1·7
10	4245	..	160	3·7	·5	1·7
6	4151	200	200	2·9	·4	1·7

§ L.—*Luminosity of a Spectrum produced by Feeble Light.*

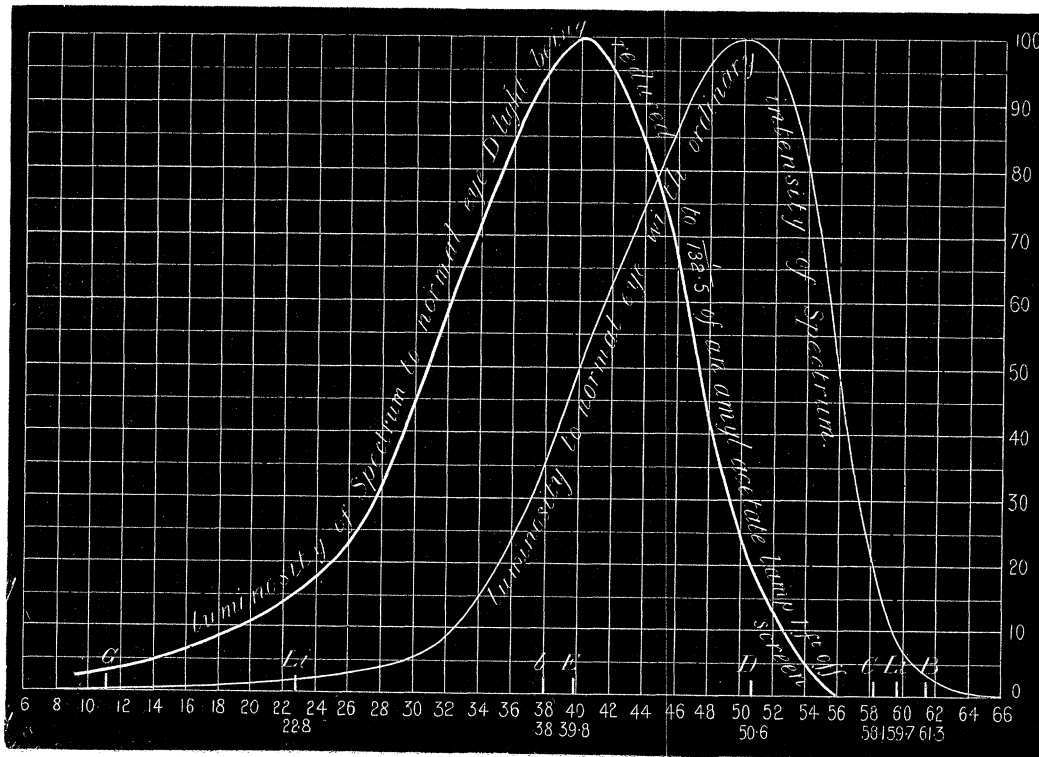
Having found that the persistency curve was apparently and presumably the same as the luminosity curve of the two persons who had but one colour sensation, it almost followed that if the beam of light producing the spectrum were sufficiently reduced its curve of luminosity would approach these. An experiment was therefore made. The reference beam was introduced into the measuring box already described (fig. 36), and, when uninterrupted by the sectors, had a luminosity of  $\frac{1}{132\cdot5}$  of an amyl lamp at one foot off. The beams from the spectrum of the colour patch apparatus were also introduced into the apparatus so that they fell as before on *S*. The luminosity of the different rays was taken in the ordinary manner interposing the rotating sectors in the reference beam. The following results were obtained (see Table XI), the mean of the readings being given. This mean in Column III. is multiplied by 1·25

Fig. 44.



Extinction and luminosity curves of a red blind.

Fig. 45.



Luminosity to a normal eye of a feeble spectrum.

to bring the maximum to 100. This curve (fig. 45), that of the monochromatic sensation, and the persistency curve are tabulated together in Table X., to show how closely they agree. Here we have a proof that the normal eye is as little sensitive to the red end of the spectrum formed from a very much reduced light as those of the two brothers when ordinary light is used. It must be remarked, however, that all colour was not entirely absent, though it was very considerably reduced in saturation. The measurements were made with some trouble at first, owing to the inclination of the eye to direct its axis to some point other than the centre of the patch where the white strip and the colour strip touch one another. The diversion of the axis of the eye in some cases made the colour more luminous, and in other cases less so, than it did when the eye was properly directed, as might be surmised from the luminosity curves of light of ordinary intensity. By reducing the light in less degrees it became possible to obtain curves of luminosity which agreed very closely with those of the different degrees of red blindness (that is, where the spectrum is shortened at the red end), of which we have had many cases to try. As already pointed out, the outer part of the retina of our own eyes is really in one stage of red blindness, having a slightly shortened spectrum.

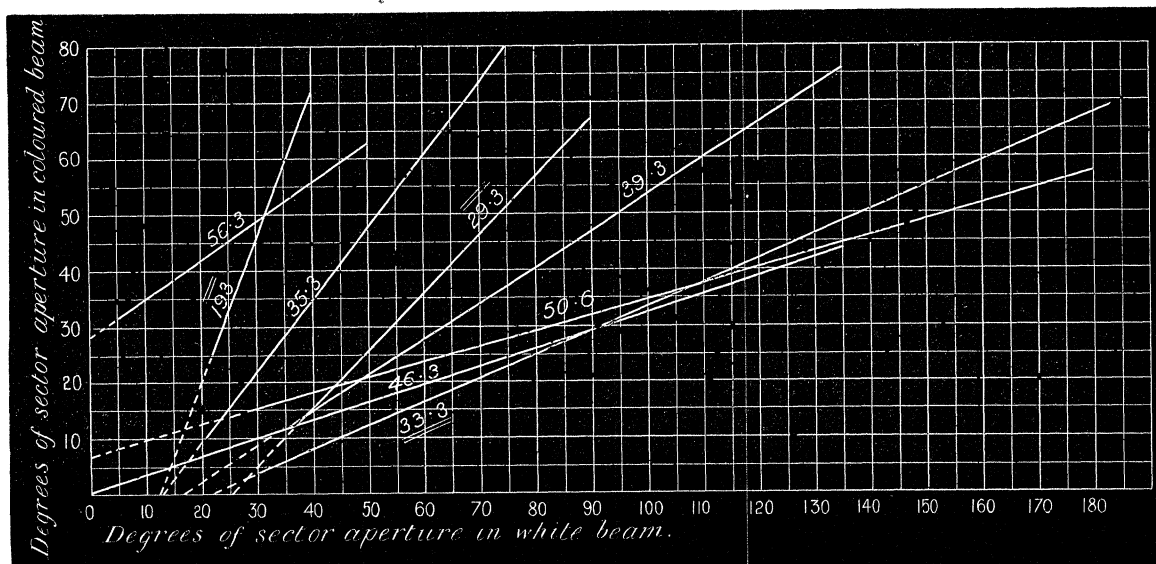
TABLE X.—Luminosity of Spectrum Reduced in Intensity so that  $D = \frac{1}{1\frac{1}{2}^{\frac{1}{3}}}$  amyl lamp 1 foot distant.

Scale number.	Mean reading.	Mean reading, reduced to 100 max.	P. and Q.'s readings, 100 max.	Persistency curve for the centre of the eye.
55·6	·5	·6	2	2
53·6	5·5	7·0	3·6	3·6
51·6	13	16·7	8	8
49·6	23	29·7	22	22
47·6	40	50·0	44	44
45·6	57	71·2	69	69
43·6	70	87·5	93	93
41·6	79	98·7	100	99·5
39·6	78	97·5	99·5	98·5
37·6	74	92·5	96	93
35·6	66	82·5	89	84
33·6	55	68·7	77·5	71
31·6	44·5	55·2	61	53·5
29·6	35	43·7	45·5	36·5
27·6	24	30·0	33·5	24
25·6	17	21·7	25	16
23·6	13	16·7	18	10
21·6	10	12·5	13	8
19·6	8	10·0	9·5	6
13·6	3	3·7	4·2	3
9·6	2	2·5	2·5	2

§ LI.—*Relative Luminosity of Rays for Different Spectrum Intensity.*

Having found that the curves of luminosity of a spectrum when feeble and when bright differed, it became a matter of some importance to ascertain in what manner the relative luminosity of the rays varied when the intensity of the light which formed the spectrum was altered in a definite ratio. Evidently the most satisfactory method of ascertaining this was to throw a patch of white light on the screen and then to diminish its luminosity to known amounts, and having selected some ray of the spectrum, to equalize their luminosities. The box already described (fig. 36) was brought into requisition, and a beam of white light was caused to illuminate one half of the white patch on the screen at the end of the box, and the other half was illuminated by the ray whose luminosity was to be tried. Rotating sectors were placed in each beam; the apertures of those in the white were fixed at different angles, whilst those of the sectors in the coloured beam were opened or closed till the luminosities appeared the same to the eye, a series of readings being taken for each ray. The results thus obtained were plotted, and some typical ones are shown

Fig. 46.



Relative luminosities of rays with different intensities of the spectrum.

in fig. 46. The ordinates are the apertures of the sectors in the monochromatic rays, and the abscissæ the apertures of the sectors in the white beam. The tangent of the inclination to the vertical of the curve at any point, therefore, represents the ratio of the luminosity of the coloured to that of the white beam for a certain intensity of light. If this ratio were the same for all intensities the curve would become a straight line starting from the origin. This is the case, it will be seen, with one ray only, that at scale number 46.3, or about  $\lambda$  5618. This ray and

white light would therefore be extinguished together. It may be more than a coincidence that this ray does not differ much in wave length from that ray which, as stated by one of us in a paper on the Transmission of Sunlight through the Earth's Atmosphere (see 'Phil. Trans.,' present volume) was found to be affected to the same degree as the integrated light of the whole spectrum, no matter what was the thickness of the atmosphere through which it had passed.

It will be seen, however, from the diagram, that the other curves become straight lines when certain degrees of intensity, different in each case, are reached; and if these straight lines are produced to cut the axis the ordinates of the rays which lie towards the blue end of the spectrum above  $46\cdot3$  have a negative value at the zero of white light, whilst those which lie toward the red side of  $46\cdot3$  have a positive value; showing that the blue part of the spectrum is extinguished last, and the red part first, as we have already seen to be the case.

It is, moreover, evident, and this has been demonstrated by experiments described above, that for low intensities the luminosity curve of the spectrum will vary with difference of intensity, but that a degree of intensity is soon reached, when all the curves have become straight lines, and that the distances from the origin at which they cut the axis are so small compared with the distance where the curves of all the rays become straight, that the relative luminosities of the different rays in spectra of ordinary intensity are practically the same. In the experiments last described, the D light on the screen when not reduced by the sectors was equivalent to  $\cdot027$  of an amyl lamp at one foot. This would bring it far beyond the point where its curve, and indeed those of all other rays, would become straight. \*

The following table shows the agreement of the results of these last measurements with those of the observations, from which the luminosity curve for the central part of the eye was constructed. The quotient of the difference of two abscissæ in the straight part of each curve divided by the difference of the corresponding ordinates evidently is the tangent of the inclination to the vertical, which, as stated above, is a measure of the luminosity of the corresponding ray. In Column V. of the table the first five of these quotients are multiplied by  $28\cdot2$  in order to make them easily comparable with the ordinates of the normal curve which are given in Column VI. In the case of the last three entries in the table, the beam of white light was necessarily diminished in intensity before it passed through the sectors, the quotients have therefore to be multiplied by  $5\cdot03$ .

\* It must be remembered that we are only dealing with light reflected from a white screen, and it does not follow that the lines may continue straight indefinitely when the light is of the brilliancy seen when looking direct at a bright spectrum, such as that of the sun, with a fairly wide slit to the collimator.

TABLE XI.—Relative Luminosities of Rays.

I.	II.	III.	IV.	V.	VI.
Scale number.	Wave-lengths.	Diff. abscissæ Diff. ordinates	Tan. of incli- nation.	Tan. × 28·2 or 5·03.	Luminosity of normal curve.
56·3	6358	$\frac{50-20}{62-42}$	1·5	42·3	43·5
50·6	5889	$\frac{180-40}{58-18}$	3·5	98·6	99·5
46·3	5618	$\frac{180}{57}$	3·16	88	88
39·3	5246	$\frac{135-45}{76-18}$	1·55	43·7	44·5
35·3	5066	$\frac{75-25}{80-15}$	·77	21·7	20·2
33·3	4975	$\frac{105}{48-4}$	2·39	12	12
29·3	4822	$\frac{50}{66-15}$	·96	4·9	5
19·3	4497	$\frac{10}{80-50}$	·33	1·68	1·5



## ADDENDUM.

(Added July 20, 1892.)

§ LIII.—*A Case of Green Monochromatic Vision.*

Since the foregoing paper was read a very phenomenal case of colour-blindness has been investigated by us for the Colour Vision Committee of the Royal Society. It is the case of a type so rare that we have not hesitated to publish it at the earliest opportunity. The patient (B. C.) had been examined by Mr. NETTLESHIP, who kindly secured his attendance at South Kensington for the purpose of being examined by the spectrum and other tests. B. C. is a youth of 19, who has served as an apprentice at sea. His form vision is perfect, and he is not night blind. He can see well at all times, though he states that on a cloudy day his vision seemed to be slightly more acute than in sunshine. He was first requested to make matches with the Holmgren wools in the usual manner, with the result that he was found to possess monochromatic vision. He matched reds, greens, blues, dark yellows, browns, greys, and purples together; and it was a matter of chance if he selected any proper match for any of the test colours. Finally, when pressed, he admitted that the whole of the heap of wools were "blue" to him, any one only differing from another in brightness. The brighter colours he called "dirty" or "pale" blue, terms which eventually proved to be synonymous. We then examined him with patches of monochromatic spectrum colours by means of the colour patch apparatus. He designated every colour as "blue," except a bright yellow, which he called white, but when the luminosity of this colour was reduced he pronounced it a good blue. So with white, as the illumination was decreased, he pronounced it to pass first into dirty blue, and then into a full blue.

MAXWELL'S discs were then brought into requisition, and it was hard at first to know how to make the necessary alterations, owing to the terms he employed to express the difference which existed between the inner disc and the outer grey ring. By noting that a pale "blue" passed into a pure blue when the amount of white in the outer ring was diminished, and that the inner disc was described as "pale" or "dirty" when the outer ring was described as a "a very full blue," we were enabled to make him match accurately a red, a green, and a blue disc separately with mixtures of black and white.

The following are the equations :—

$$360 \text{ red} = 315 \text{ black} + 45 \text{ white.}$$

$$360 \text{ green} = 258 \text{ black} + 102 \text{ white.}$$

$$360 \text{ blue} = 305 \text{ black} + 55 \text{ white.}$$

With these proportions he emphatically stated that all were good blues, and that the inner disc and outer ring were identical in brightness and in colour.

It may be remarked that this is a case of congenital colour blindness, and that there is reason to believe that some of his ancestors were colour blind.

Before using the discs an attempt was made to ascertain the luminosity of the spectrum as it appeared to him. His readings, however, were so erratic that nothing could be made out from these first observations, except to fix the place of maximum luminosity, the terms "pale" and "dirty" puzzling us as to their real meanings. After the experience with the discs we had a clue as to what he wished to express by pale or dirty blue, which only meant that the colour or white was too bright, and on making a second attempt he matched the luminosities of the two shadows as easily as did P. and Q., the other cases of monochromatic vision. The method adopted was to diminish the white light illuminating one shadow to the point at which he pronounced it a good blue, when a slight alteration in the intensity was always sufficient to secure to his eye equality of luminosity between it and the coloured shadow without his perceiving any alteration in the saturation.

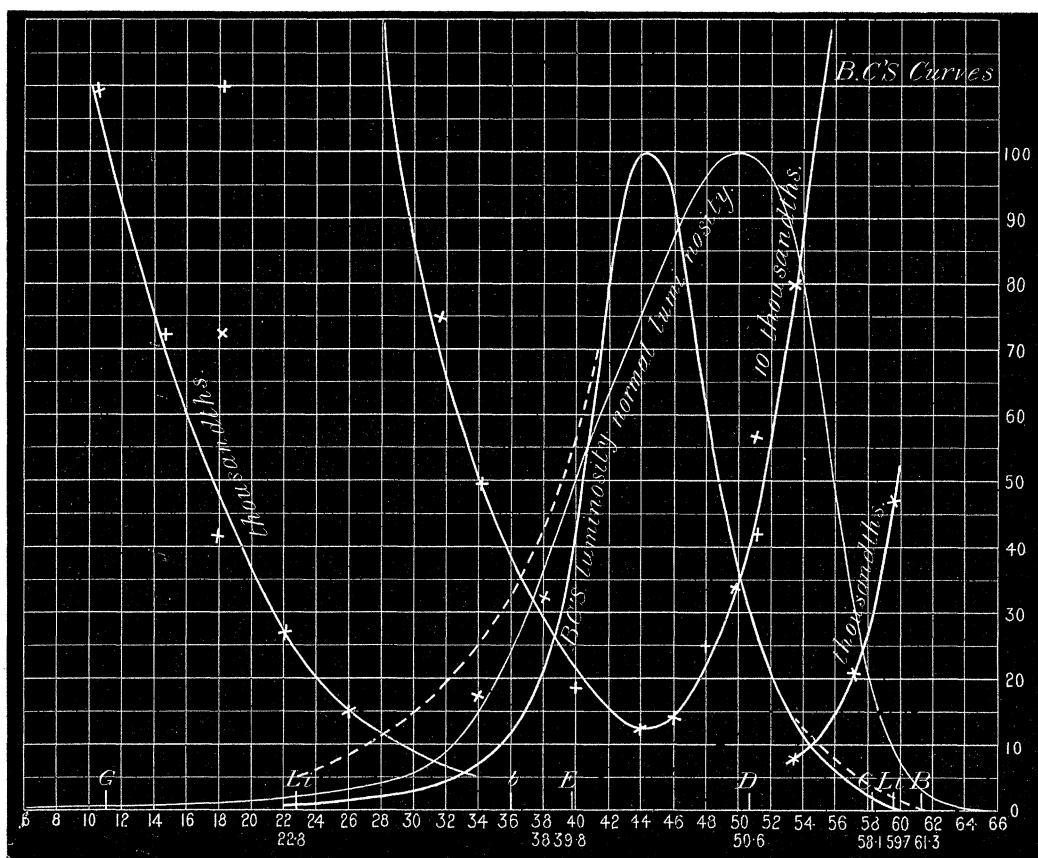
The curve of luminosity, fig. 47, is a very remarkable one, being different in character to that of P. and Q., the maximum being well on the D side of E. A great falling off in the luminosity when compared with that measured by the normal eye will be noticed both in the blue and in the red. The evidence was, therefore, presumptive that B. C.'s colour sensation was neither red nor blue, but probably a green.

The next test was made to throw light on this point. He made observations of the extinction of the different parts of the spectrum (see § XLVIII.). His observations were very fair, except on the violet side of F, where they became slightly erratic, but by requesting him to use all parts of his retina to obtain the last glimpse of light, a very concordant curve resulted, as shown in fig. 47. Some of his observations at this part were evidently made with the centre of the retina, for they gave readings which, when the "persistency" curve was calculated, and these observations treated as part of the extinction, agreed with the luminosity curve. We may, therefore, conclude that B. C. has a region in the retina in which there is an absorbing medium corresponding to the yellow spot of the normal eyed. This is diagrammatically shown in fig. 47 by the difference in height of ordinates in the persistency and the luminosity curves. On the red side of the maximum the two curves are practically identical, except from Scale number 54. At this point for similar reasons, as given in § XLVIII., it is probable that the white light which illuminated the prism vitiated the readings to some degree, as Column VI. of the following table shows. At the violet end something similar, doubtless, occurs, but it is masked by the difference in extinction by the central part of the retina and that of the whole eye.

It must, however, be remarked that the amount of reduction of the intensity of a ray to produce extinction is very different for B. C. and for the normal eyed, or for the red- and green-blind or for P. and Q. B. C. can bear nearly 200 times less

reduction for the rays near E. We have already pointed out that the same is practically the case with M., whom we presume to be violet blind. We may therefore deduce the fact that the monochromatic vision in this case is of a totally different type to that of P. and Q., and that the last sensation to be lost is the same as that of M. If any violet sensation were present in either, the fact would be made evident by the order of the extinction. The sensation of B. C. is thus apparently the green sensation, though that this particular sensation is exactly the same as that absent in the green blind is not certain; his curve agrees very closely in form and position with that deduced by KÖENIG by different methods as that of the green sensation.

Fig. 47.



B. C.'s luminosity and extinction curves.

## ON COLOUR PHOTOMETRY.

565

TABLE XII.--B. C.'s Curves.

I.	II.	III.	IV.	V.	VI.
Scale number.	Wave-length.	Adopted reading in hundred thousandths.	Persistency curve, 12,500 readings in V.	Luminosity of original beam.	Absolute luminosity of extinction III. and V.
61	6839	7,500	1.6		
60	6728	5,500	2.3	.5	27.5
59	6622	4,000	3.1	1	40
58	6520	2,800	4.5	2	56
57	6423	2,000	6.2	4	80
56	6330	1,500	8.3	6	90
55	6242	1,150	10.8	8	92
54	6152	950	13.1	11.5	109.2
53	6074	750	16.6	16	120
52	5996	580	21.6	21.5	125
51	5919	430	29	28.5	122.5
50	5850	350	36	37	129.5
49	5783	275	45.5	47	129.2
48	5720	215	58	60	129
47	5658	170	73.4	76	129.2
46	5596	140	89.3	92	129
45	5538	125	100	98	122.5
44	5481	125	100	100	125
43	5427	130	96.1	97	126
42	5373	150	83	85	127.5
41	5321	180	69.4	65	117
40	5270	215	59	45	96.7
39	5221	250	50	30	75
38	5172	290	43	21.5	72.3
37	5128	335	37	16	53.6
36	5055	380	33	11.5	43.7
34	5002	500	25	7	35
32	4994	650	19	4	26
30	4848	850	14	2.5	23.3
28	4776	1,100	11.4	2	22
26	4707	1,500	8.3	1.5	22
24	4639	2,000	6.2	1	20
22	4578	2,700	4.6	5	13.5
18	4459	4,750			
14	4349	7,500			
10	4245	11,000			